

性能表/Performance table

泵型号 Model	参考型号 Reference model	功率 Power P ₂ (kW)	流量 Q (m ³ /h)	8.0	10	12	14	15	16	18	20	22	24
CVLA15-1		1.1	扬程 H (m)	14	13	12	11.5	11	10.5	10	9	8	7
CVLA15-2	CDLF16-2	2.2		26	25	24	23	22	21	20	18	16	14
CVLA15-3	CDLF16-3	3.0		39	38	37	34	33	31	29	27	24	20
CVLA15-4	CDLF16-4	4.0		52	50	48	46	44	43	40	36	31	26
CVLA15-5	CDLF16-5	4.0		66	64	61	58	56	54	50	45	39	33
CVLA15-6	CDLF16-6	5.5		80	78	75	70	67	65	60	54	47	41
CVLA15-7	CDLF16-7	5.5		94	92	88	83	80	78	71	64	56	50
CVLA15-8	CDLF16-8	7.5		108	105	101	96	93	90	83	75	66	57
CVLA15-9	CDLF16-9	7.5		122	119	115	109	104	98	93	87	77	66
CVLA15-10	CDLF16-10	11		136	133	128	123	120	116	107	98	86	76
CVLA15-12	CDLF16-12	11		158	155	150	144	140	135	126	116	102	89
CVLA15-14	CDLF16-14	11		183	178	172	165	162	156	145	133	118	103
CVLA15-16	CDLF16-16	15		210	204	197	190	185	179	168	153	137	118
CVLA15-17		15		218	212	203	198	193	188	171	155	136	125

安装图/Installation sketch

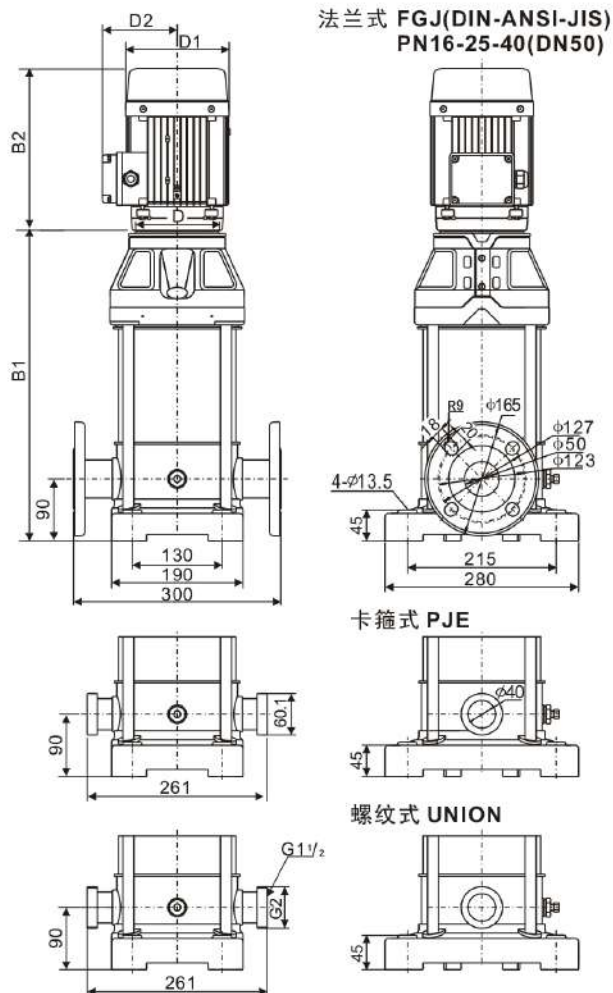

泵型号 Model	尺寸/Dimensions(mm)											
	单相 single phase					三相 Three phase					D	
	B1	B2	B1+B2	D1	D2	B1	B2	B1+B2	D1	D2	V18	V1
CVLA15-1	336	240	576	150	118	336	240	576	150	118	121	-
CVLA15-2	393	300	693	168	147	393	280	673	168	127	135	-
CVLA15-3	-	-	-	-	-	438	300	738	168	127	135	-
CVLA15-4	-	-	-	-	-	493	323	816	200	146	145	-
CVLA15-5	-	-	-	-	-	538	323	861	200	146	145	-
CVLA15-6	-	-	-	-	-	608	379	987	212	160	185	300
CVLA15-7	-	-	-	-	-	653	379	1032	212	160	185	300
CVLA15-8	-	-	-	-	-	698	417	1115	212	160	185	300
CVLA15-9	-	-	-	-	-	743	417	1160	212	160	185	300
CVLA15-10	-	-	-	-	-	873	448	1321	255	178	250	350
CVLA15-12	-	-	-	-	-	963	448	1411	255	178	250	350
CVLA15-14	-	-	-	-	-	1053	448	1501	255	178	250	350
CVLA15-16	-	-	-	-	-	1143	489	1632	255	178	250	350
CVLA15-17	-	-	-	-	-	1188	489	1677	255	178	250	350

性能曲线/Performance Curve

CVLA15-50Hz

